

LCLS-II Technical Note

Temperature Rise in LCLS-II Cavity Bellows

LCLS-II TN-15-22

06-29-2015

Arun Saini, Nikolay Solyak, V. Yakovlev, A.
Sukhanov, A. Lunin



July 3



Fermilab

Jefferson Lab

Abstract

Studies are performed to evaluate temperature rise in the cavity bellows in an accelerating cryomodule of 4 GeV superconducting (SC) linac that would be built for the Linac Coherent Light Source –II (LCLS-II) facility at SLAC. This note presents estimation of temperature rise in the stainless steel and copper bellows. Implications of copper coating (inner and outer) on a stainless steel bellows are also discussed.

1 Introduction

The LCLS-II is a proposed free electron laser (FEL) facility that is planned to be built at SLAC. This facility is primarily based on a 4 GeV continuous wave (CW) SC linac. A detailed description of SC linac is presented elsewhere [1].

Major sources and their contributions to RF losses in an accelerating cryomodule are summarized in Table 1. RF losses are estimated for the beam operation with bunch charge of 300 pC and repetition rate of 1MHz. We use cavity accelerating gradient of 16 MV/m in this estimation. The total power of 0.6 W dissipates over nine copper -coated bellows in a cryomodule.

Table 1: Dynamic losses in an accelerating cryomodule for the beam operation with bunch charge of 300 pC and repetition rate of 1 MHz [2].

Loss Origin	Cavity [8]	HOM Coupler & Pickup [16+8]				Bellow [9]	Flange [16+6]	Power Coupler [8]				Σ [n] [W/CM]		
		Rad	Loss					PC	Gate Valve	End Pipe	HOM Absorb			
Operating Mode ^[1,2,3,4,5] (16 MV/m)	10.1 W [81 W]	Peak				2 mW [0.02 W]	60 mW [0.5 W]	0.2 W [1.6 W]	2 W [16 W]	17 W [136 W]	83 W	16.4 W	137 W	
		8 W	0.05 W	0.12 W	0.34 W									
HOM Resonance ^[6] (< 10GHz)	Peak				0.1 W	10 mW	PC	Gate Valve	End Pipe	HOM Absorb	0.15 W	0.05 W	0.1 W	
	0.1 W	10 W	0.25 W	0.6 W										2 W
Beam Wake	Radiated ^[7]	[13.8 W]	[0.3 W]			[0.5 W]	[0.01 W]	[0.2 W]	-	-	-	14.8 W		
	Transient Loss ^[8] >0.7 THz	[0.9 W]	13 mW [0.3 W]	[0.02 W]	[0.05 W]	[0.1 W]	30 mW [0.3 W]	10 mW [0.2 W]	[0.05 W] [0.65 W]	0.15 W [0.3 W]	0.1 W [0.1 W]	11.4 W [11.4 W]	1.9 W	0.6 W 11.4 W
	Resistive Loss (ASE) ^[9]	-	-	-	-	20mW [0.2 W]	-	-	25 mW [0.05 W]	0.1 W [0.1 W]	[0.1 W]	0.4 W	-	0.1 W
Total Loss [W/CM]		82 W	23 W	0.2 W	0.5 W	1.2 W	0.6 W	0.7 W	1.6 W	0.25 W	0.2 W	148 W	86 W	17 W 149 W

[n] – number of elements in cryomodule

2K 5K 70K

2 Temperature Profile in Bellows

The cavity bellows is cooled down by process of conduction cooling. Thus, heat removal in the bellows is not as efficient as in the cavities. Thus, additional power dissipation in the bellows results in a temperature rise. Because of high vacuum, heat transfer due to the convection is negligible and if neglect the radiation contribution in heat transfer at cryogenic temperature, heat transfer is primarily governed by the process of the conduction. Assuming heat transfer is mostly in one dimension, temperature profile in a bellows can be evaluated using 1-D steady state heat diffusion equation as shown below:

$$\frac{\partial}{\partial z} \left(k(T) \frac{\partial T}{\partial z} \right) = - \frac{\left(\dot{q}(z + \delta z) - \dot{q}(z) \right)}{dz}; \quad (1)$$

If we consider rate of heat deposition is uniform, we could re-write equation (1) as following:

$$\frac{\partial}{\partial z} \left(k(T) \frac{\partial T}{\partial z} \right) = - \dot{q} \quad (2)$$

where k is thermal conductivity, \dot{q} is rate of heat deposited per unit volume. Assuming thermal conductivity is independent of temperature; solution of equation (2) can be expressed as following:

$$T(z) = - \frac{\dot{q}}{2k} z^2 + \left[\left(\frac{T(L) - T(0)}{L} \right) + \frac{\dot{q}}{2k} L \right] z + T(0) \quad (3)$$

where $T(L)$ and $T(0)$ are temperatures at both ends and L is effective length of bellows. In order to find the solution of equation (2) that includes temperature dependence of thermal conductivity, we define a variable U

$$U = \int k(T) dT ; \quad (4)$$

Thus we could write:

$$\begin{aligned} \frac{\partial U}{\partial z} &= \frac{\partial U}{\partial T} \frac{\partial T}{\partial z}; \\ \therefore \frac{\partial U}{\partial z} &= k \frac{\partial T}{\partial z} ; \end{aligned} \quad (5)$$

Using equation (5) we could rewrite equation (2) as following:

$$\frac{\partial^2 U}{\partial z^2} = - \dot{q} \quad (6)$$

Solution of equation (6) is:

$$U = \int_{T_1}^T k(T) dT = -\frac{\dot{q}}{2} z^2 + Az + B ; \quad (7)$$

where A and B are constants of integration and one can find their values using boundary conditions. If we consider Temperature is fixed at both ends i.e. $T(0) = T(L) = T1$, equation (7) becomes:

$$\int_{T_1}^T k(T) dT = -\frac{\dot{q}}{2} z^2 + \frac{\dot{q}L}{2} z ; \quad (8)$$

One can estimate temperature T (upper limit of integration) that satisfies equation (8) for the power dissipation of \dot{q} at a given location.

In order to estimate temperature profile in a bellow, we modelled bellows as a cylindrical pipe. Solving equation (8) using following numbers, one can evaluate temperature profiles in the bellows

$L=392.14 \text{ mm}$; Bellows thickness = 0.3 mm ; Radius of Bellows = 39 mm ; $T(L) = 4 \text{ K}$; $T(0) = 4\text{K}$.

2.1 Temperature Rise in copper bellows

Copper of RRR ranging from 30 to 80 is to be used for the coating on the stainless steel bellow. In order to find maximum rise in temperature for worst case, we use copper thermal conductivity corresponding to RRR 30.

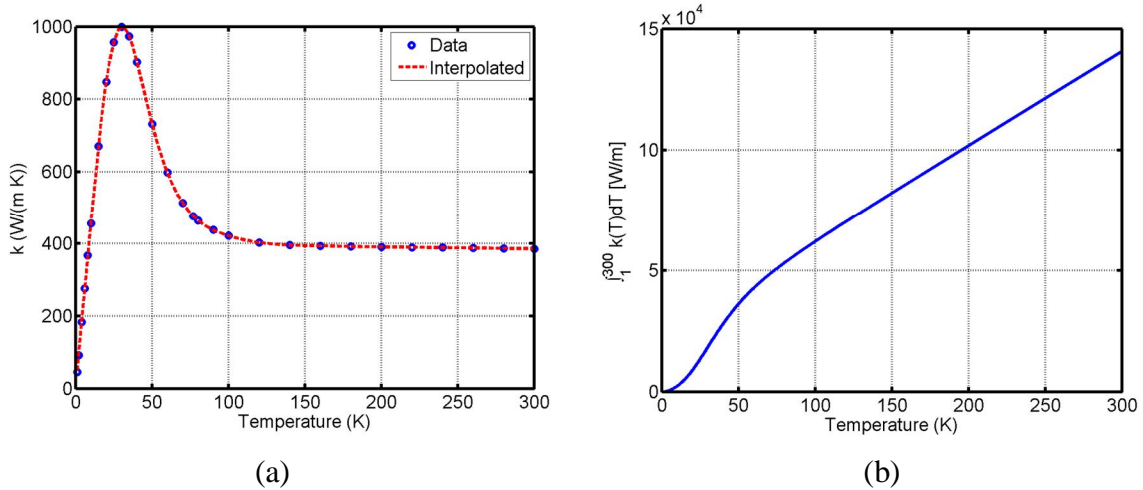

Figure 1: (a) Thermal conductivity of copper of RRR 30 and (b) Integrated thermal conductivity over temperature range from 1K to 300 K.

Figure 1 (a) shows temperature dependence of thermal conductivity [3]. We use spline function to interpolate experimentally measured data. Figure 1 (b) shows integrated thermal conductivity (U) over the temperature range 1K to 300 K.

In case, bellows is made of copper, one can estimate the temperature profile using this information. Temperature evolution in bellows is evaluated for two cases. First, we consider thermal conductivity of copper remains constant along the bellows and

thermal conductivity of 184 W/(m K) corresponding to temperature 4K is applied. In later case, temperature dependence of thermal conductivity is included Figure 2 shows temperature profile along bellows for power dissipation of $\sim 67\text{mW}$.

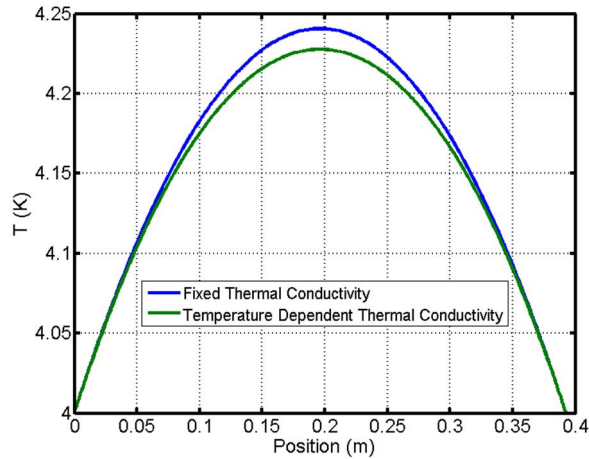

Figure 2: Temperature evolution along copper bellows for fixed (blue) and temperature dependent thermal conductivity (green).

2.2 Temperature profile in stainless steel bellows

If bellows is made of stainless steel, total power dissipation (P) in a bellows due to different sources is about $\sim 1.17\text{ W}$. Figure 3 (a) and figure 3 (b) show evolution of thermal conductivity [3] and integrated thermal conductivity respectively for given range of temperature.

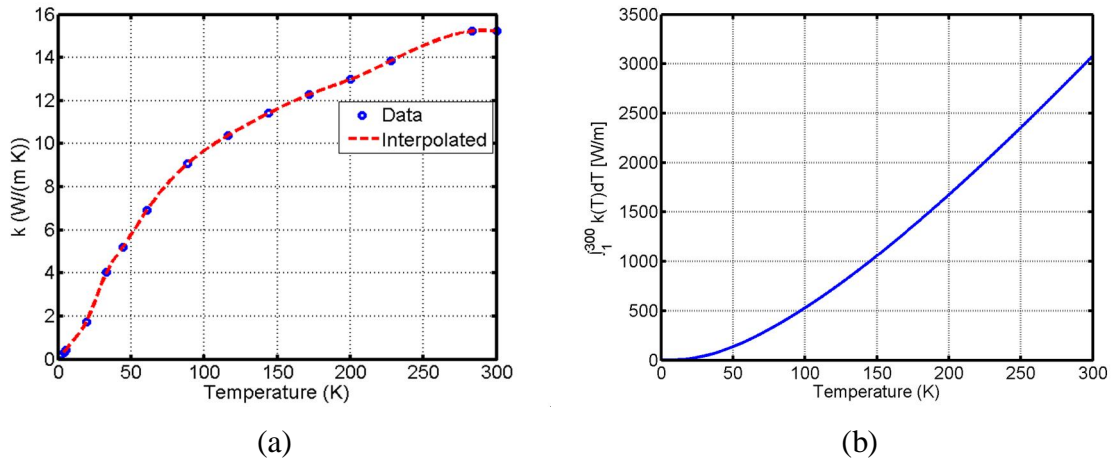

Figure 3: (a) Thermal Conductivity of Stainless Steel 304 and (b) integrated thermal conductivity for the temperature range from 1K to 300 K.

Figure 4 shows temperature profile along stainless steel bellows. Stainless steel has very low thermal conductivity at cryogenic temperature. It can be observed from figure 4 (a) if a fixed thermal conductivity at 4K i.e. 0.3 W/ (m-K) is used in estimation; there is an enormous temperature rise in bellows. However, if temperature dependence of thermal conductivity is included, maximum temperature in bellows is about 125 K as

shown in figure 4 (b). Figure 5 shows variation in thermal conductivity along the length of bellows.

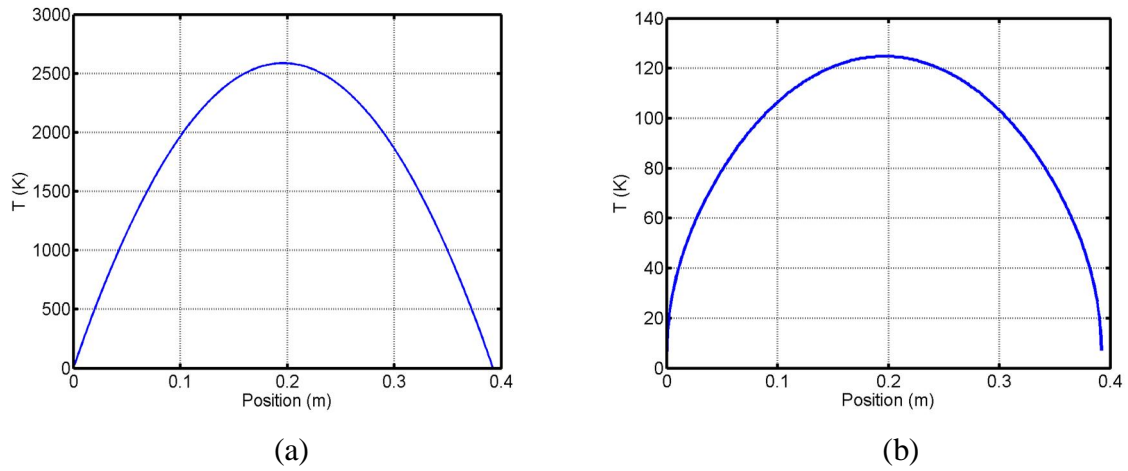

Figure 4: Temperature evolution in stainless steel bellows (a) for fixed thermal conductivity and (b) temperature dependent conductivity.

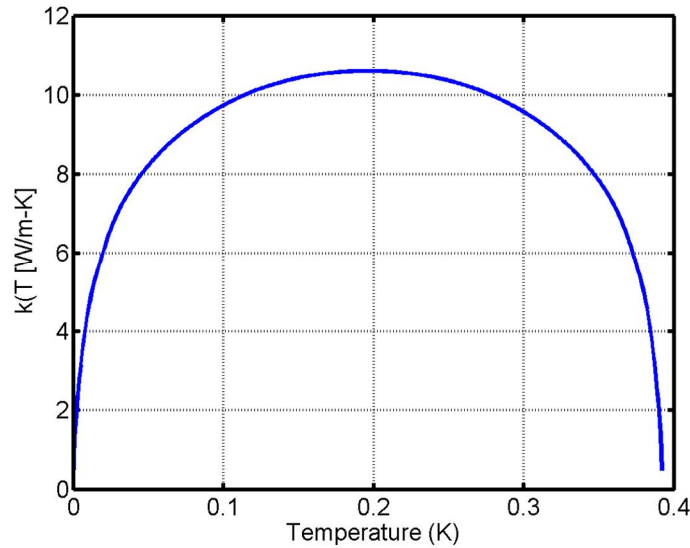

Figure 5: Variation in thermal conductivity of SS 304 along bellows

2.3 Copper coating on stainless steel bellows

A coating of good thermal conducting material on an element made of poor thermal conducting material is commonly used to improve heat conduction through this element.

Ratio of thermal conductivity of copper-RRR 30 to thermal conductivity of stainless steel-304 at 4 K is ~ 600 . Thus, a coating of copper on stainless steel bellows helps to improve heat conduction across the bellows and consequently a decrease in temperature rise. In order to analyze heat conduction in a multilayer coated system, we use network approach. Similar to electrical resistance, we introduce concept of thermal

resistance. Figure 6 shows analogy between electrical and thermal resistance.

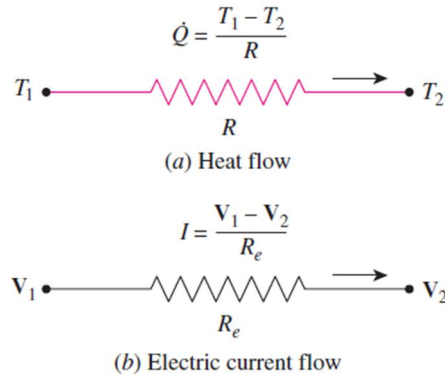

Figure 6: Analogy between thermal and electrical resistance.

Thermal resistance R of the wall against heat conduction is expressed as:

$$R = \frac{L}{kA} \quad (5)$$

Applying fixed temperature at both ends, maximum temperature rise is obtained at $z = L/2$ which is given as:

$$\Delta T(L/2) = \frac{P L}{8 kA} ; \quad (6)$$

In terms of thermal resistance, equation (6) can be expressed as:

$$\Delta T(L/2) = P.R_n ; \quad (7)$$

where R_n is net resistance.

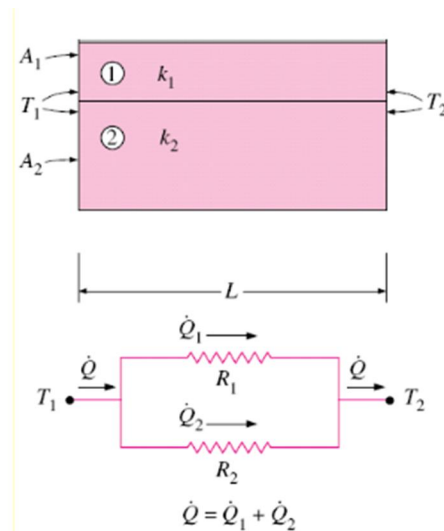

Figure 6: Pictorial representation of a multilayer system.

If a bellows is coated with a material of thermal conductivity k_2 on a material of thermal conductivity k_1 and area of cross section for each material is A_1 and A_2

respectively, then conduction resistance of a coated bellows can be estimated using a parallel network model as shown in Figure 6. Thus, net thermal resistance of the coated bellows is

$$\frac{1}{R_n} = \frac{1}{R_1} + \frac{1}{R_2};$$

$$R_n = \frac{R_1 R_2}{R_1 + R_2}; \quad (8)$$

Using the R from equation (6), R_n is expressed as:

$$R_n = \frac{L}{8(k_1 A_1 + k_2 A_2)}; \quad (9)$$

Inserting this value of R_n in equation (7) one can easily estimate maximum temperature rise in a coated bellows. It is worth to note that we neglect contact thermal resistance in this estimation.

2.3.1 Inner Copper Coating

Copper has higher electrical and thermal conductivity than stainless steel. Thus, a coating of copper on the bellows not only results in significant reduction of RF losses but also enhances overall thermal conductivity of bellows. Consequently, total power dissipation and therefore, temperature rise in the bellows is also small. According to LCLS-II cryomodule specifications, an inner copper coating of 15 mm +/- 5 mm is used on stainless steel bellows.

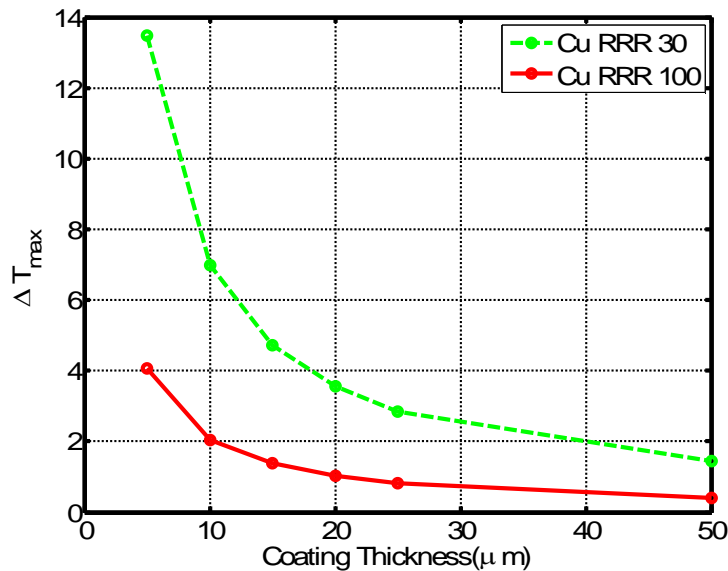

Figure 7: Variation in maximum temperature rise in bellows with inner coating thickness.

Figure 7 shows variation in maximum temperature rise (ΔT_{\max}) with inner coating thickness of copper. We use thermal conductivity of copper and stainless steel at 4 K in this evaluation. Estimation is performed for copper of RRR 30 and RRR 100.

2.3.2 Outer Copper Coating

Outer coating of copper does not help to reduce RF losses but it improves thermal conductivity of bellows. Figure 8 shows variation in maximum temperature rise with thickness of outer copper coating on bellows.

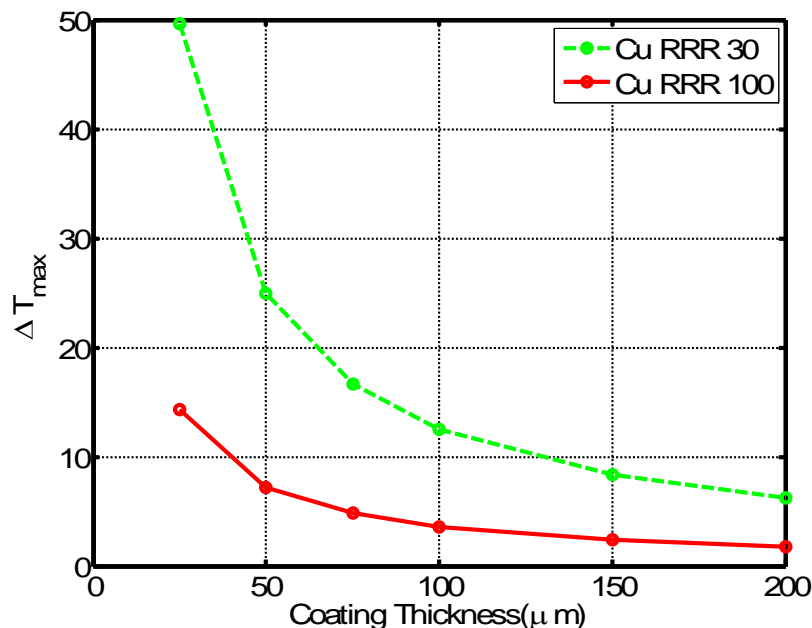

Figure 8: Variation in maximum temperature rise in bellows with outer coating thickness.

3 Conclusion

Stainless steel is a poor thermal conducting material. A study shows that temperature rise in a stainless steel bellows is about ~ 125 K even for a power dissipation of ~ 1.17 W. This makes it an unfavorable choice for the bellows in a LCLS-II cryomodule. However a copper coating (inner or outer) on stainless steel bellows reduces temperature rise significantly. An inner coating of thickness 15 mm results in maximum temperature rise less than 5 K and 2 K for copper of RRR 30 and 100 respectively.

REFERENCES

- [1] "Development of the Superconducting 3.9 GHz Accelerating cavity at Fermilab," N. Solyak et al. <http://lss.fnal.gov/archive/2005/conf/fermilab-conf-05-121-td.pdf>
- [2] "Dynamic Heat Loads in the 1.3 GHz LCLS-II Production Cryomodule," Engineering note 0179, Fermilab.
- [3] <http://indico.cern.ch/event/194284/contribution/7/material/4/0.pdf>.