

REV	DESCRIPTION	DWN	CHKR	APVD	DATE
1	ADDED DETAIL B, SURF TEXT WAS 8, R .010 WAS INTERIOR ONLY, ADDED FLATNESS.	CLI	DW		20NOV 2012
2	GENERALLY REDIMENSIONED AND RETOLERANCED COMPLETE PART. ADDED 1MM BOSS. ADDED NOTES 2-5.	GB	DW	DW	11-29 2012

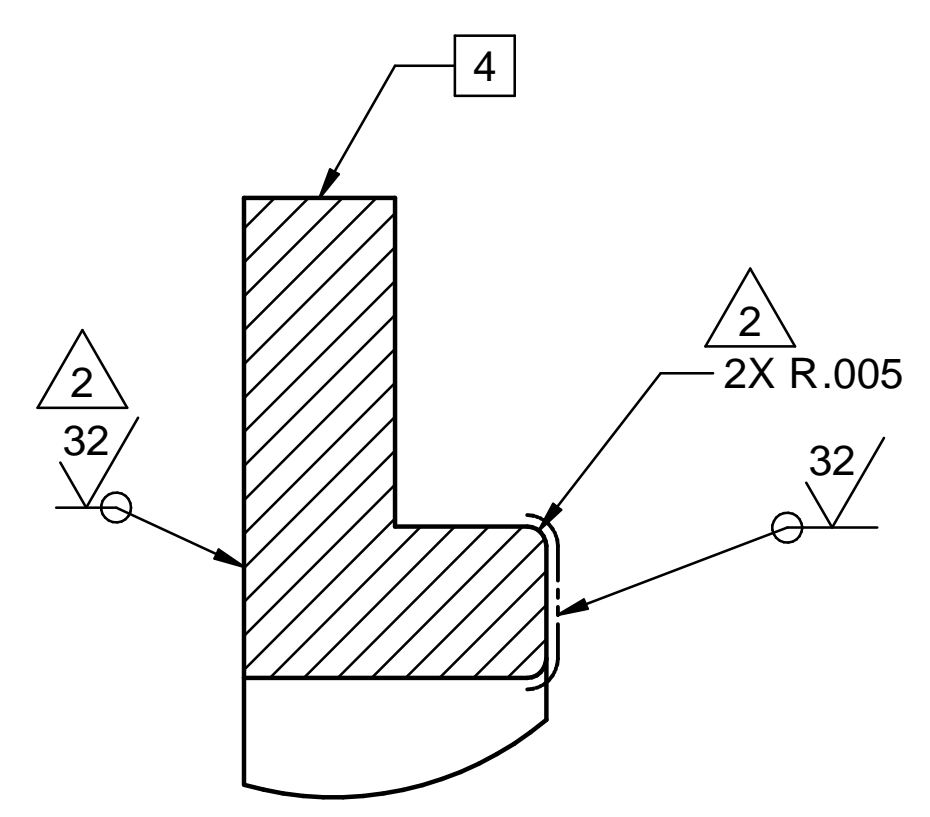
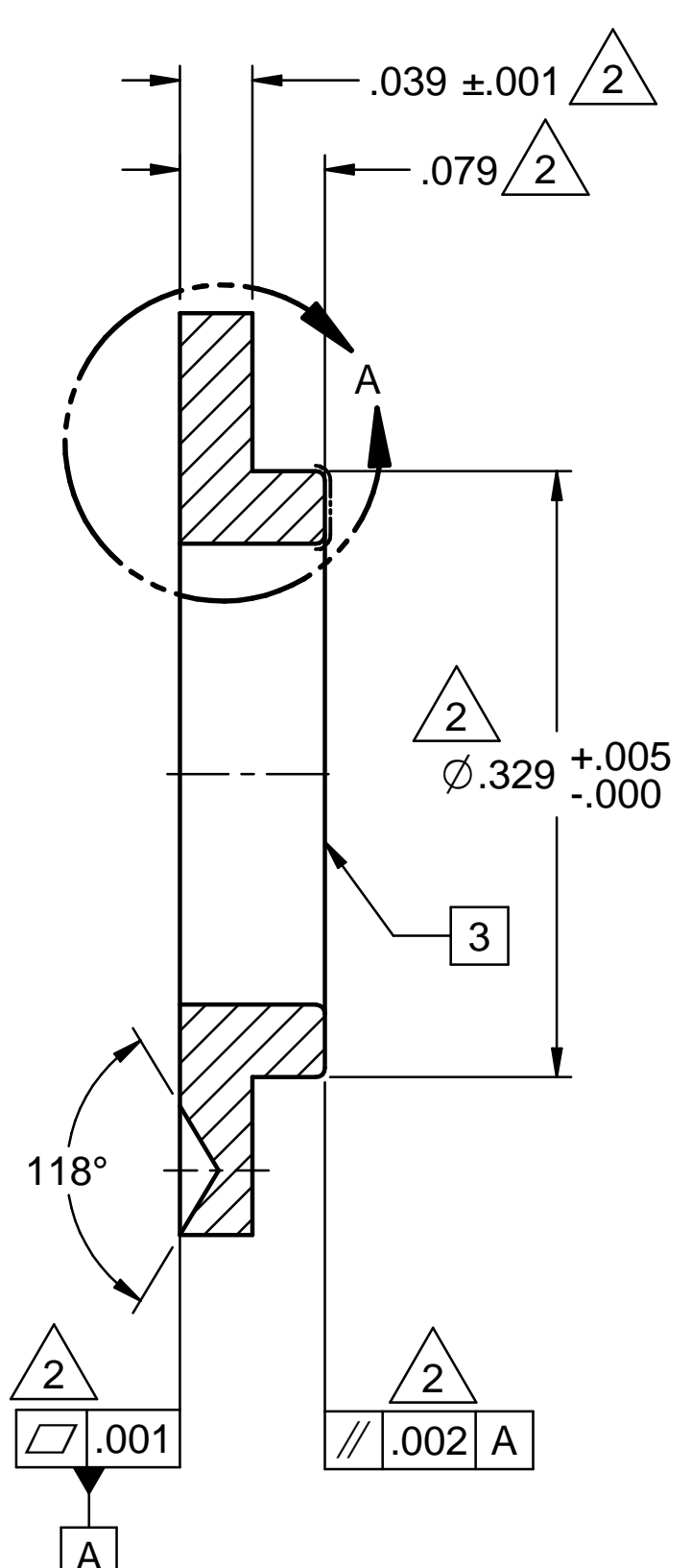
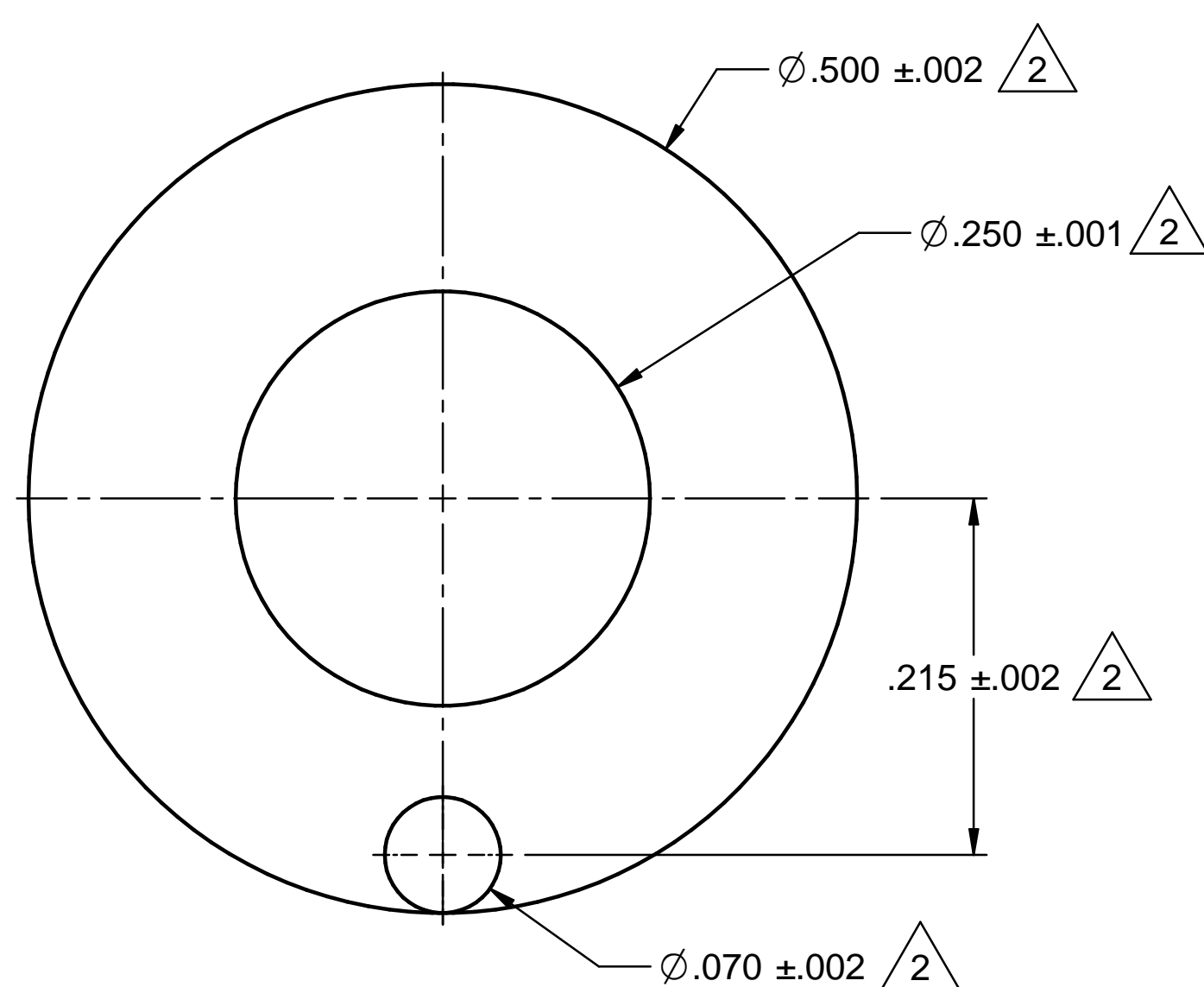

- NOTES: UNLESS OTHERWISE SPECIFIED
- 1 MATERIAL: SST PLATE OR SHEET, IN ACCORDANCE WITH ASTM A240. MILL SOURCE CERTIFICATES REQUIRED, INCLUDING HEAT NUMBER AND CHEMICAL ANALYSIS.
 - 2 PART FABRICATOR: LEBOW COMPANY
PHONE: (805 964-7117
CONTACT: EDWARD GRAPER
 - 3 EPOXY APPLIED ON THIS SURFACE: EMERSON AND CUMING, ECCOBOND 55 WITH 12% CATYLIST, TESTED AND APPROVED.
 - 4 HANDLE PART WITH TWEEZERS ONLY, ON OUTER EDGE. DO NOT TOUCH FOIL.
 - 5 BAG AND TAG WITH PART NUMBER AND REV LEVEL.

ULTRA HIGH VAC PART
FABRICATE PER FP-202-631-14

SST AISI TYPE 304	
STOCK NO	MATERIAL DESCRIPTION

---	DIMENSIONING AND TOLERANCING IS IAW ASME Y14.5M-1994 AND Y14.41-2003	SCALE: 10:1 DO NOT SCALE DRAWING	CAD FILE NAME: pf25740289-2.dft
---	UNLESS OTHERWISE SPECIFIED DIMENSIONS ARE IN INCHES. TOLERANCES: BREAK EDGES .005-.015 INTERNAL CORNERS R.015 MAX FRACTIONS ± --- DEC .XX± --- .XXX± .005 .XXXX± --- ANGLE ± .5° ALL SURF 32	SLAC NATIONAL ACCELERATOR LABORATORY	U.S. DEPARTMENT OF ENERGY
---	SA-257-402-85	THE DRAWINGS, SPECIFICATIONS AND OTHER DATA HEREIN PROVIDED SHALL NOT BE COPIED, PUBLISHED OR OTHERWISE FURTHER DISSEMINATED WITHOUT PRIOR WRITTEN PERMISSION OF STANFORD UNIVERSITY/SLAC	
---	NEXT ASSEMBLIES:	ENGR D. WALZ DWN G. BOUCHARD 11/16/2012 CHKR D. WALZ	APPROVALS D. WALZ C. IVERSON
ESTIMATED MASS .002 lbm		FACET DIAGNOSTICS SYSTEMS OTR FOIL MOUNT ASSY FOIL MOUNT RING, .5 DIA	
		DRAWING NUMBER PF-257-402-89	REVISION NUMBER 2 C

FACET DIAG OTR FOIL MOUNT RING

PF-257-402-89 2 SH 1 OF 1